

Special models type RTX with more teeth

To Excavators in the class 0-60 ton

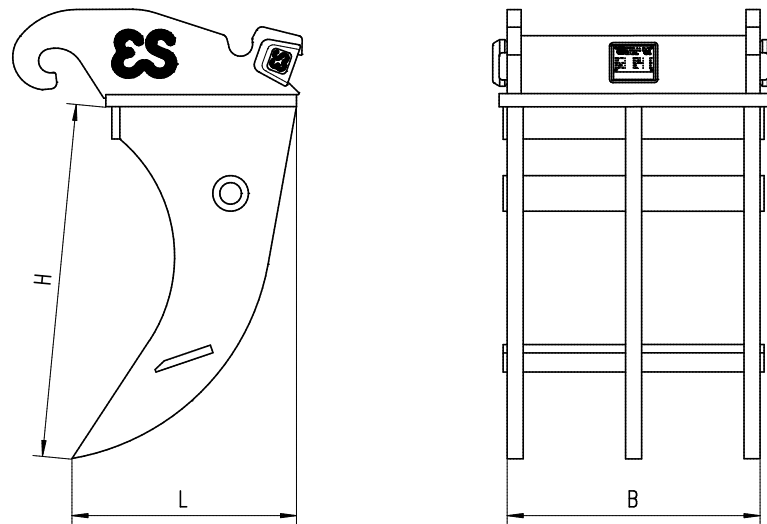

**Intended for light break-out activities and
uprooting tree stumps**



Type	B (mm)	L (mm)	H (mm)	Weight (kg)
RTX.00.3TAND	400	225	295	35 kg
RTX.00.4TAND	415	225	295	30 kg
RTX.0.1TAND.SP	250	277	600	50 kg
RTX.1.3TAND.SP	400	374	600	130 kg
RTX.1.4TAND	600	374	600	130 kg
RTX.4.2TAND	670	559	885	340 kg
RTX.4.3TAND	670	559	885	425 kg
RTX.4.5TAND	670	559	885	605 kg
RTX.4.8TAND	1800	559	885	1060 kg

Characteristics of Ripper with more teeth:

- Intended for light break-out work and uprooting tree stumps
- Strong construction of high-quality materials, enables low maintenance and long lifetime
- Designed with several wear resistant teeth
- Several other versions and widths possible on request

Eurosteel BV

Van Heemskerckweg 10

5928 LL Venlo

The Netherlands

T: +31 (0)77 387 60 60

F: +31 (0)77 382 49 47

E: info@eurosteel.nl