

## Hydraulic model type PFWH

To Wheel loaders in the class 14-22 ton

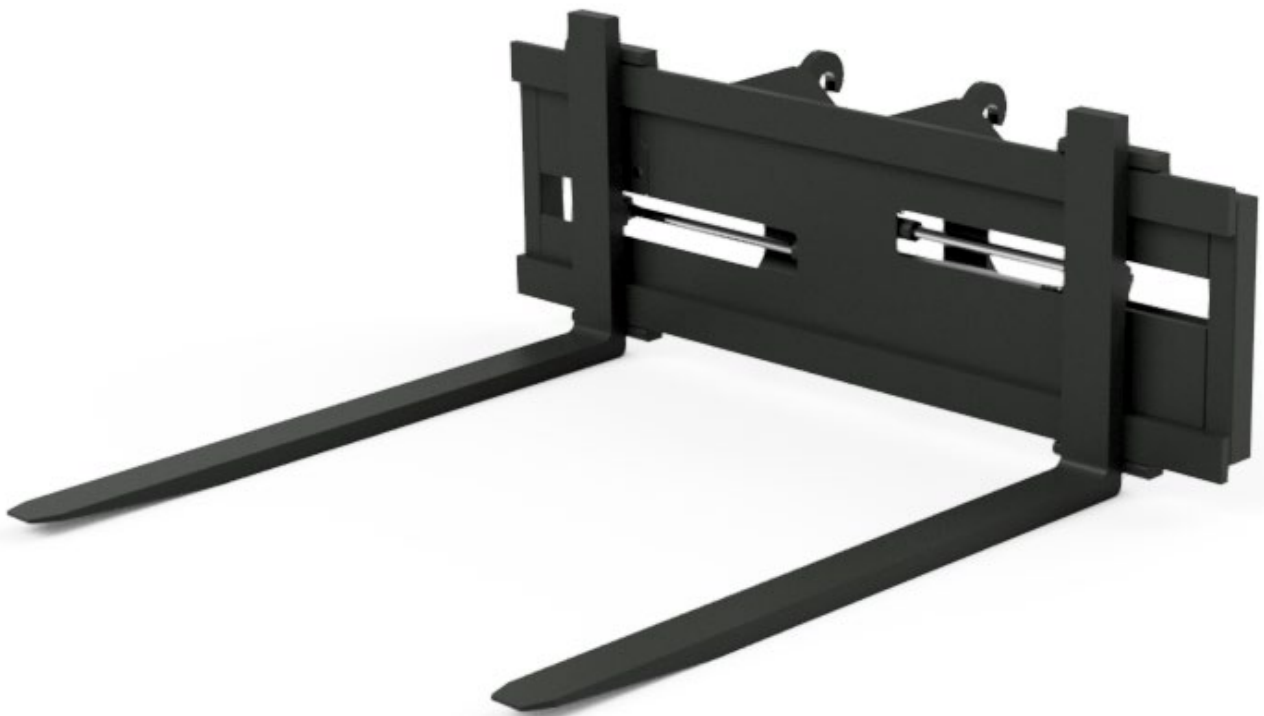

**Intended for quick and easy transfer of  
various materials**

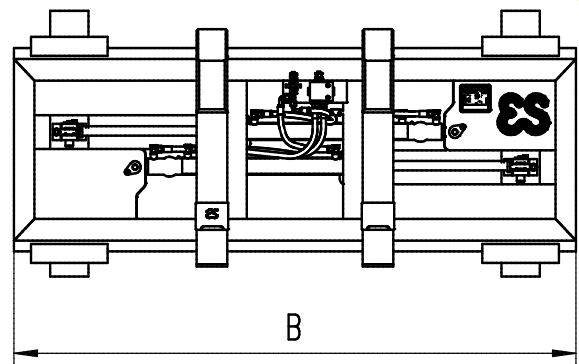
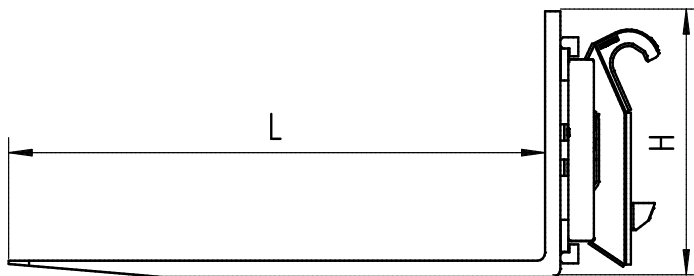

Type	B (mm)	L (mm)	H (mm)	Load (max)	Weight (kg)
PFWH.6.2000.190	2000	1900	980	7000 kg	930 kg
PFWH.7.2000.190	2000	1900	1245	9000 kg	1130 kg

## Characteristics of hydraulically operated palletfork:

- Intended for quick and easy transfer of various materials
- Forks hydraulically operated by 2 cylinders
- Strong construction of high quality materials leads to low maintenance and longer lifetime
- Available with universal fork lengths for proper functionality
- Several versions and widths possible on request

### Eurosteel BV

Van Heemskerckweg 10

5928 LL Venlo

The Netherlands

T: +31 (0)77 387 60 60

F: +31 (0)77 382 49 47

E: [info@eurosteel.nl](mailto:info@eurosteel.nl)